

Swedish Monumentality/  
Småland House

Terrence Hector

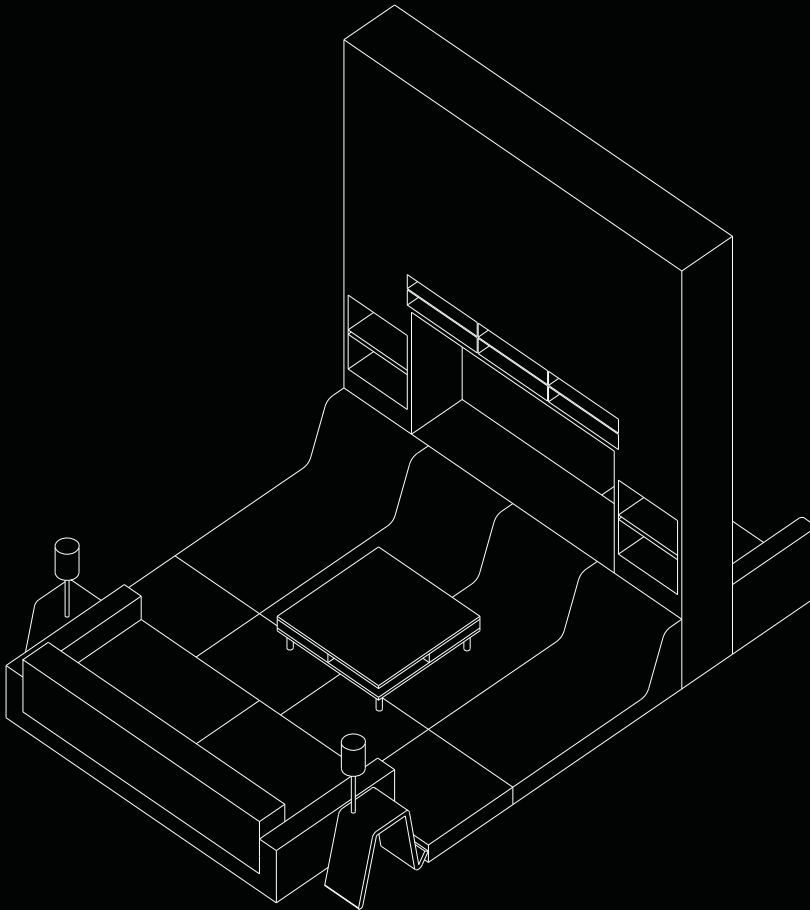



Swedish  
Monumentality/  
Småland  
House

Terrence Hector  
UIC SoA Fall 2014  
Dean/Gibson

# Swedish Monumentality

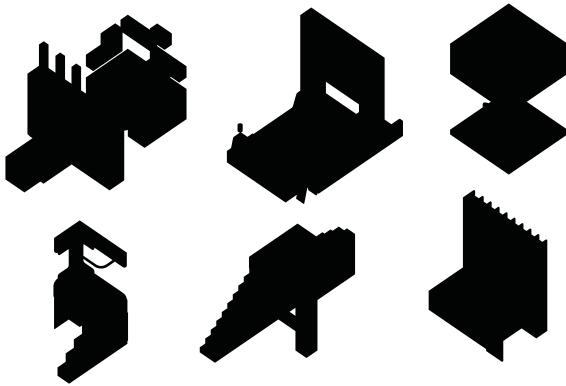

Combining the Client's tastes for both custom furniture and generic Ikea pieces, the monumental furniture in this house is made up entirely of Ikea pieces and parts. The furniture takes on qualities of Ettore Sottsass / Memphis Group furniture, in which the furniture becomes architectural, pushing against the space while life occurs in the resulting nooks and crannies. The pieces become so large and all-encompassing that one piece is the equivalent of a room.

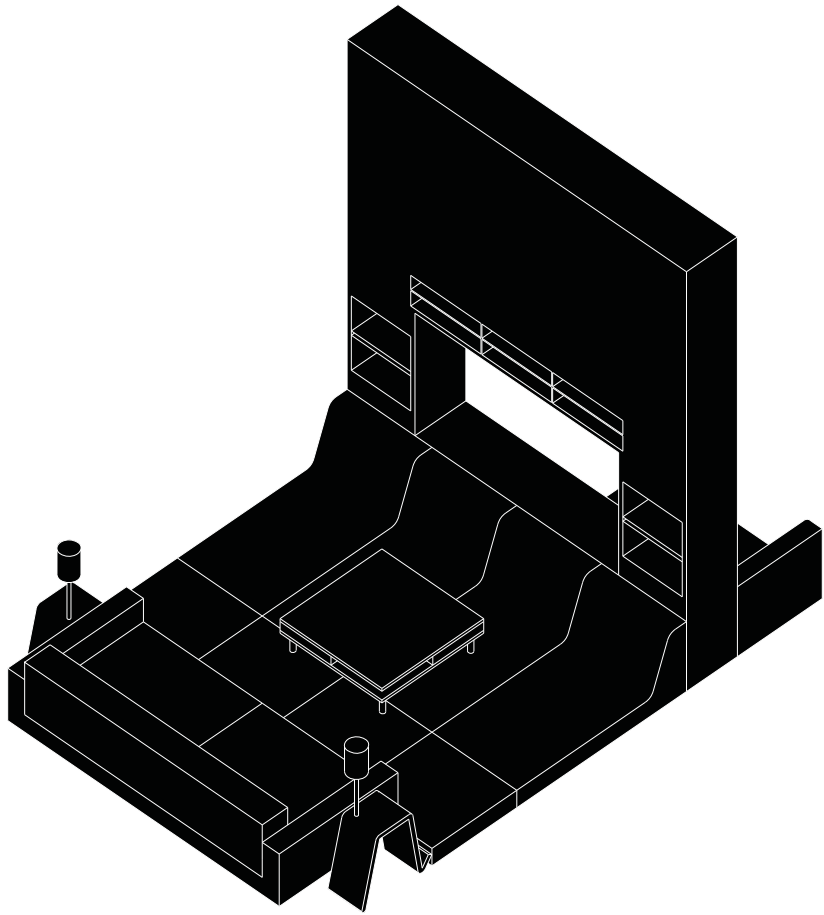

Living Room

Bestå  
Nockeby  
Karlstad  
Tofteryd  
PS 2014

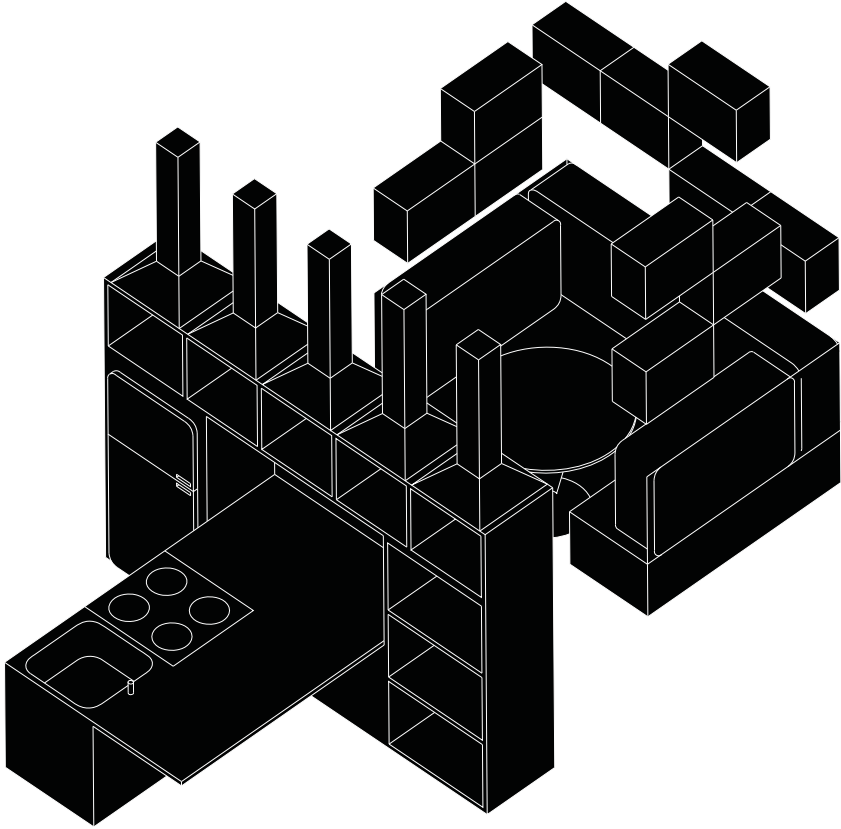



Kitchen/Dining

Nockeby

Bestå

Docksta

Billy

Nutid

Kylig 18

Dåtid

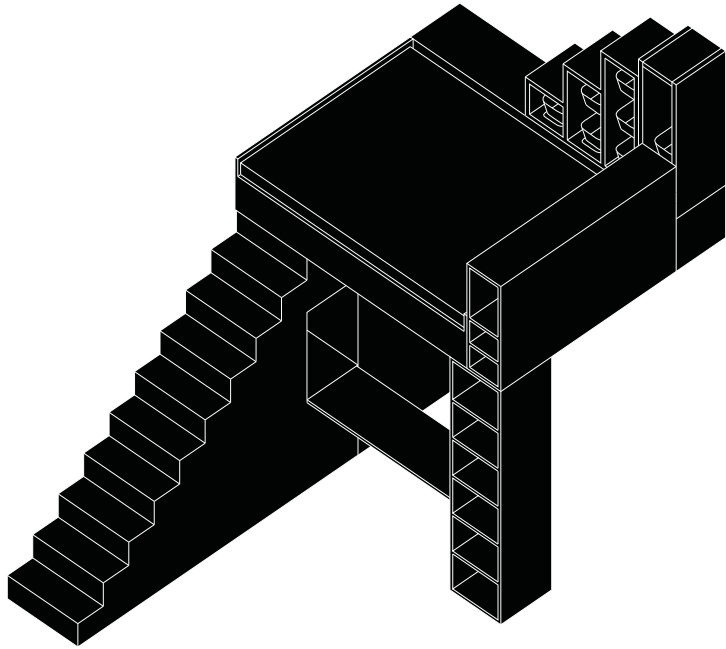

Master Bedroom

Brimnes

Pax

Billy

Lack

Trofast

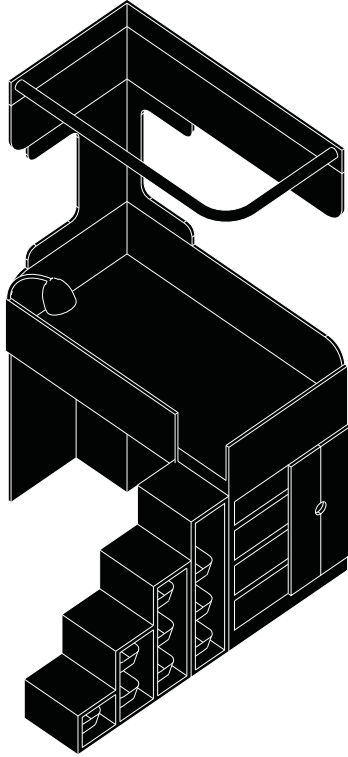

## **Kid's Bedroom**

Stuva  
Busunge  
Trofast

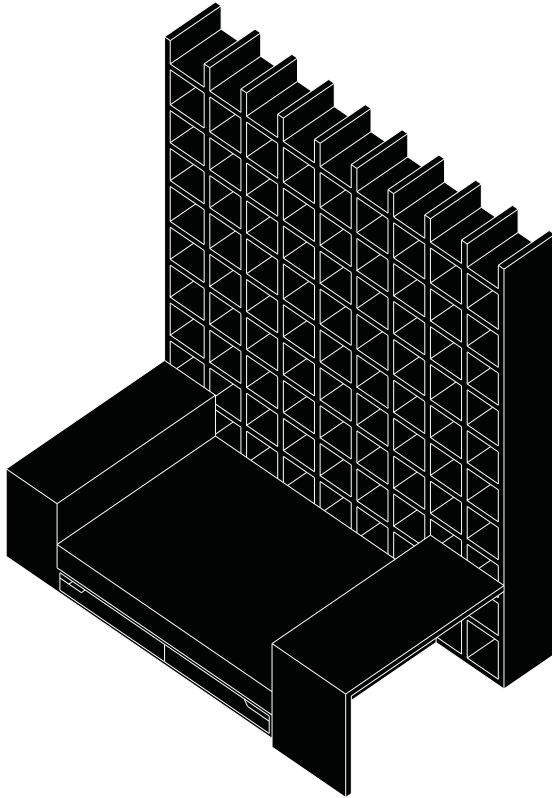

Guest Bedroom

Billy  
Mandal  
Malm  
Lack

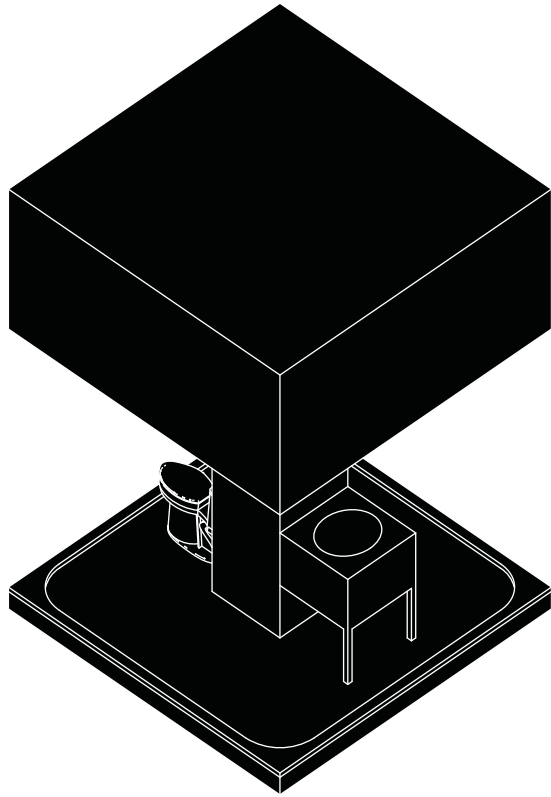



Bathroom

Godmorgon/Bråviken

Gunnern

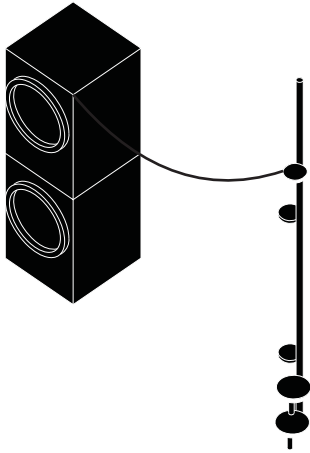

Laundry

PS 2014

# Småland House



The house is encompassed by a large roof that reaches down to the ground, and skylights are pitched up to highlight each piece of furniture. Shadows of the furniture are cast from several directions, and the overlapping results are expressed in a multi-faceted veneer pattern that reflects the geometry of each piece of furniture.

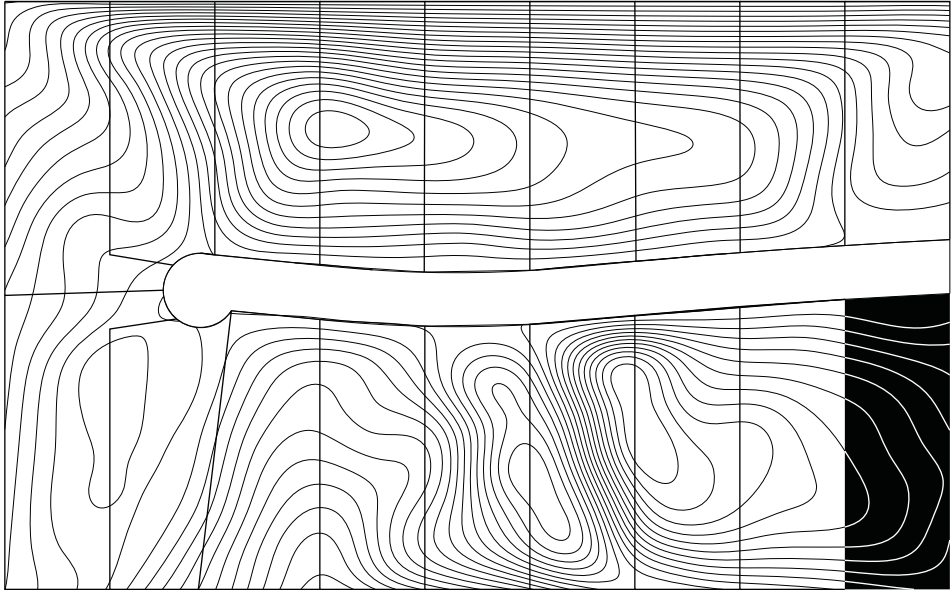

Site Plan

Lot LW-02

Envelope

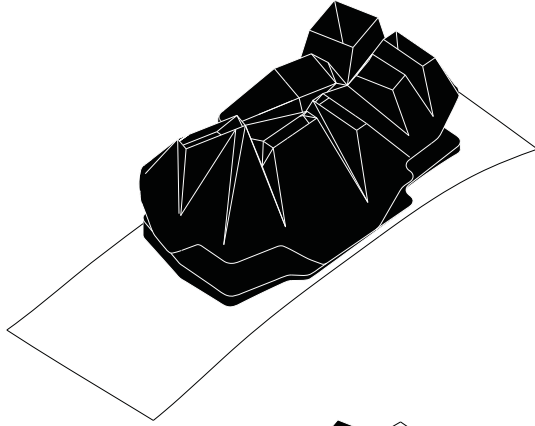

Furniture Placement

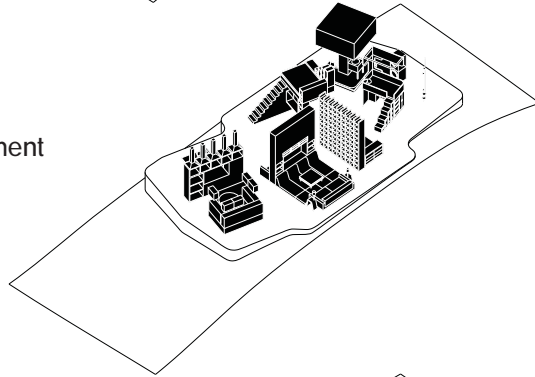

Floor Pattern

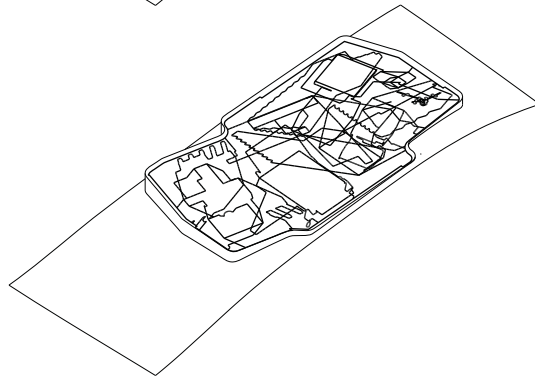



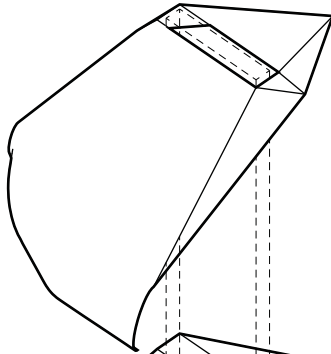

Shingled Roof

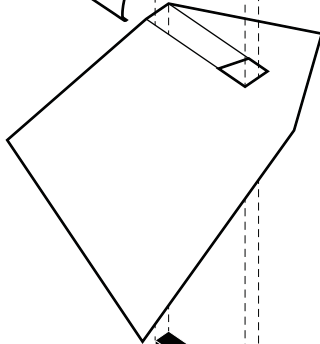

Tufted Acoustic Ceiling

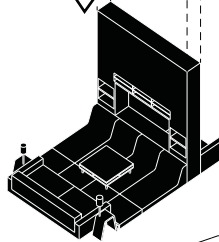

Monumental Furniture

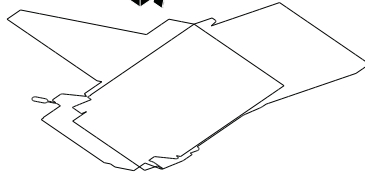

Projected Shadow Wood Floor

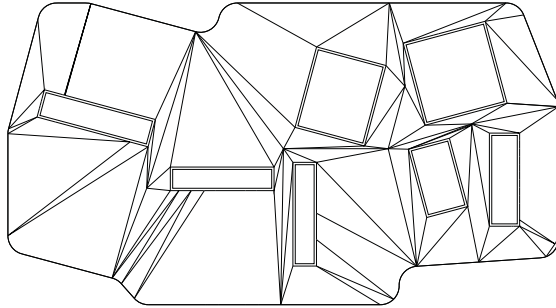

Reflected Ceiling Plan

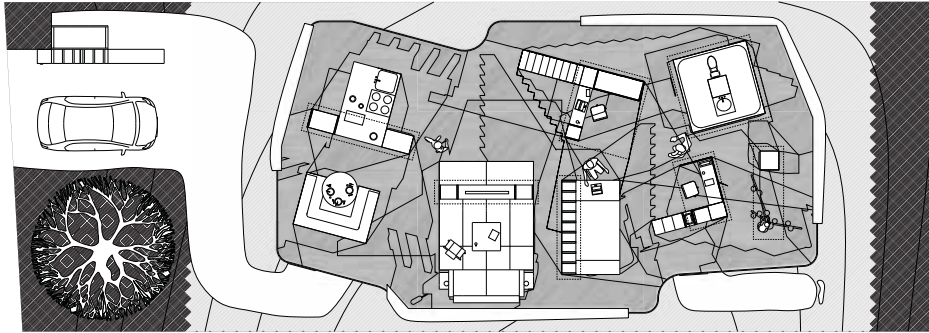

Ground/First Floor Plan

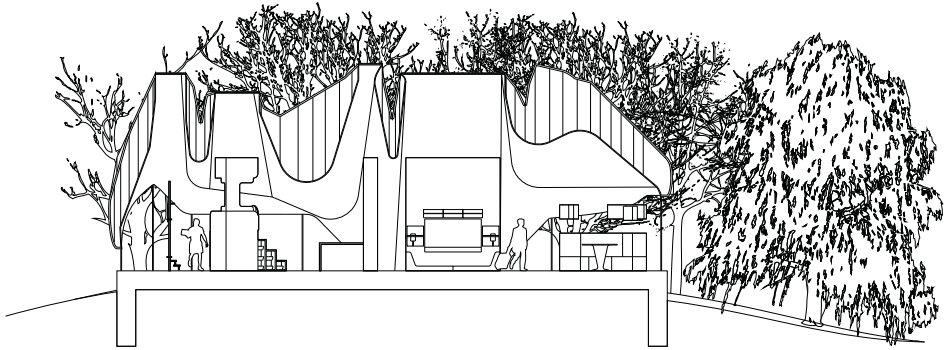

Longitudinal Section

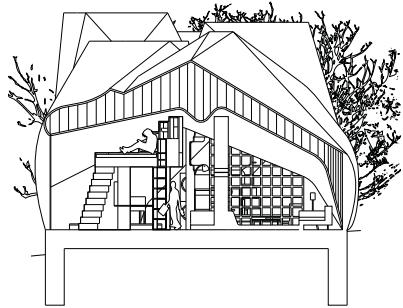

Cross Section

Elevations

